

Swivel Lifting Point Elongated Grade 80

Features

- 360 degree swivel with 180 degree pivot function
- Bolts are metric thread grade 10.9 alloy
- 100% magnaflux crack detection, 20,000 cycle fatigue tested
- Hoist ring and bail are manufactured from quenched and tempered, forged alloy steel
- Applications: Machinery and various lifting and lashing applications
- Standard and long bolt available.

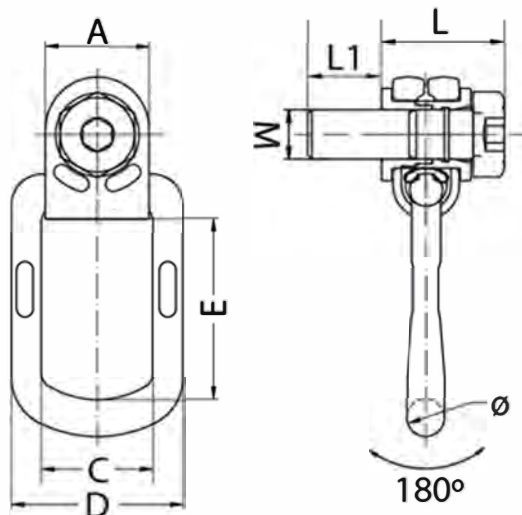

SIZE	WLL (T)	WT (KG)	BL (T)	Ø	A	C	D	E	M	L1	L
M8	0.3	0.3	1.2	14	30	35	55	52.5	8	76	35.6
M10	0.63	0.43	2.52	14	30	35	55	52.5	10	96	36
M12	1	0.8	4	18	36	40	68	54	12	114	44
M14	1.22	0.86	4.8	18	36	40	68	54	14	140	45
M16	1.5	0.92	6	18	36	40	68	54	16	194	46
M18	2	1.47	8	16	50	54	83	80	18	180	57
M20	2.5	1.49	10	16	50	54	83	80	20	187	58
M24	4	1.89	16	18	50	54	83	94	24	222	60
M27	4	5.22	16	27	68	73	119	106	27	270	82
M30	5	5.35	20	27	68	73	119	106	30	279	84